

**AVENGEANGEL®**

**Dark Knight tank**  
**Dual-Spectrum Vehicle-mounted**  
**Thermal Camera**  
**Product Specification**



## Table of Contents

1 Product Information .....	1
1.1 Product Description.....	1
1.2 Composition .....	1
1.3 Specifications .....	2
2 Control Interface Description.....	4
2.1 Structure, Dimensions and Interfaces.....	4
2.2 Electrical Interface Description.....	5
3 Product Installation and Debugging.....	6
3.1 Product Installation Methods .....	6
3.1.1 Disk-type.....	6
3.1.2 Screw-type Rigid Installation with Brackets.....	7
3.1.3 Screw-type Rigid Installation without Brackets.....	8
3.2 Product Cable Connection.....	9
3.2.1 Camera Connection.....	9
3.2.2 Power Supply for the Product .....	9
4 Product Use and Operation .....	9
5 Common Faults and Troubleshooting .....	11
6 Transportation and Storage .....	12

This Specification is used as a guide. The photos, graphics, diagrams, and illustrations provided in this Specification are for description and explanation purposes only, and there may be differences with the specific products. Please refer to the actual product. We do our best effort to ensure the information in this Specification is accurate, but we do not make any explicit or implicit statements or warranties for this Specification.

This Specification may be updated according to product version upgrades or other needs. For the latest specification version, please contact us timely. It is recommended that you use this Specification under the guidance of a professional.

### **Historical Versions**

Version	Date	Description
V1.0.0	2024.1.11	Initial version
V1.0.1	2024.4.2	Changed the optional specification of the aviation cable
V1.0.2	2024.6.6	Updated the cover image of the product specification and canceled the sun shade
V1.0.3	2024.10.14	Adjust packaging information and ensure accuracy of some information
V1.0.4	2024.12.02	Adjust the FOV

## 1 Product Information

### 1.1 Product Description

The Spike BF series, a dual-spectrum vehicle-mounted thermal camera, features an integrated high-sensitivity infrared thermal imaging detector and a 1920×1080 minimum illumination detector. It offers dual-spectrum fusion and multiple palette mode capabilities. It is specifically developed for specialty vehicles as a photoelectric acquisition, transmission, and control micro-system. The device employs infrared night vision with high- reliability and quality and black-and-white cameras with minimum illumination to capture driving images. These images are transmitted in real-time to an in-vehicle display terminal for driving observation, compliant with the all-weather driving requirements under harsh conditions such as complete darkness, heavy fog, dense smoke, and sandstorms.

### 1.2 Composition

The product safety box includes: dual-spectrum vehicle-mounted thermal camera, sun shade (optional), aviation cable, and product certificate. See Table 1 for product completeness.

Table 1 Product Completeness

S/N	Item
1	Dual-Spectrum Vehicle-mounted Thermal Camera
2	Aviation cable (optional for 3m/6m)
3	Product Certificate
4	Safety box

In order to ensure the transportation safety of the device, all accessories of the device are wrapped by square sponge, and then put into the safety box, which is made of ABS material. The diagram of the device and accessories is shown in Figure 1.

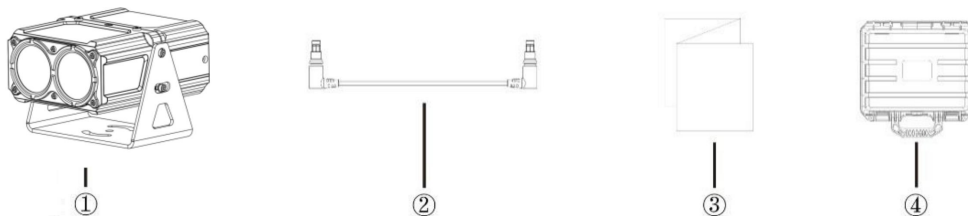

Figure 1 Diagram of the Spike BF Device and Accessories

### 1.3 Specifications

Table 2 Specifications

Model		SpikeBF55	SpikeBF90
<b>Performance Characteristics</b>			
Infrared	Type	Uncooled VOx infrared detector	
	Resolution	640×512	640×512
	Pixel Pitch	12μm	12μm
	Frame Rate	50Hz	50Hz
	Lens Type	Athermalized lens	Athermalized lens
	Focus Length	6.9m/F1.0	5.3mm/F1.0
	FOV	58°×48°±5%	90°×65°±5%
Minimum Illumination	Resolution	1920×1080	1920×1080
	Pixel Size	4μm	4μm
	Focus Length	8mm/F1.0	5.3mm/F1.0
	FOV	55°×31°±5%	85°×45°±5%
Fusion FOV		55°×30°±5%	85°×45°±5%
Startup Time		≤15S	
Latency		≤60ms (Excluding display system)	
<b>Function Characteristics</b>			
Image Mode		Supports switching between visible light, infrared, and fusion mode	
Image Adjustment		Supports image enhancement and adjustment of contrast and brightness	
Palette Fusion Mode		Night, snow, city, jungle, desert, urban	
Window Defogging and Heating		Supports manual and automatic mode	
Serial Port Firmware Upgrade		Support	
<b>Power Supply System</b>			
Power Supply		9~36VDC	
Power Consumption		≤6W (≤15W defrosting@12V)	
Reverse Connection Protection of Power Supply		Features reverse connection and undervoltage protection	
<b>Interface Information</b>			
Video Interface		PAL/SDI	
Communication Interface		RS232/CAN	

**AVENGEANGEL** Dark Knight tank Dual-Spectrum Vehicle-mounted Thermal Camera Product Specification

Physical Characteristics		
Dimensions (mm) (Excluding Bracket and Sun Shades)	116×66×133±1mm	
Weight (Kg)	≤1.5	
Recognition Distance		
Human Target (1.7m×0.5m)	150	100
Vehicle Target (2.3m×2.3m)	200	120
Environmental Parameters		
Operating Temperature	-40°C ~ +70°C	
Waterproof Grade	IP67	
Shock	40g/11ms final peak sawtooth wave; three axes and six directions; three times in each direction	
Vibration	GJB 150.16A-2009, Table D.12	
Electromagnetic Compatibility	GJB151A	

## 2 Control Interface Description

### 2.1 Structure, Dimensions and Interfaces

For detailed information on the product's structure, dimensions, and interfaces, please refer to Figure 2.

Figure 2 Product Structure, Dimensions and Interfaces

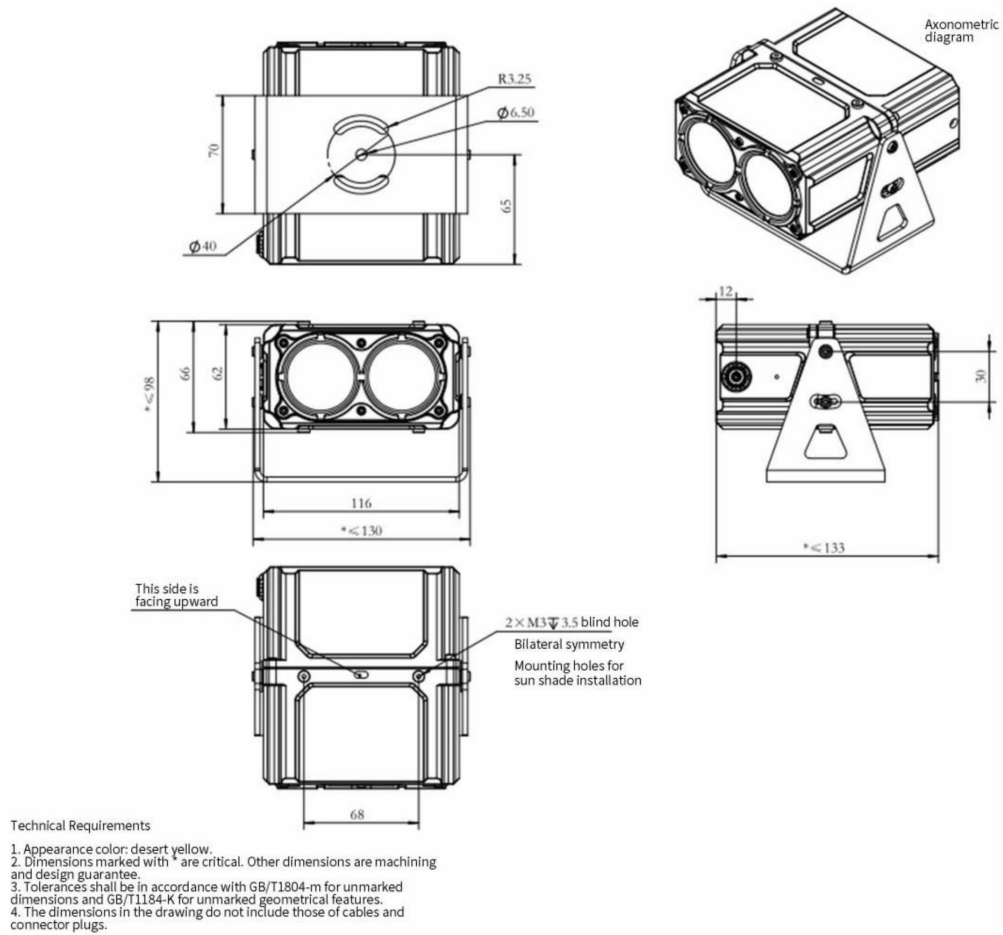

## 2.2 Electrical Interface Description

The model of product's electrical interface connector is ZGA.1U.809.KLL-1-75 (Black) (see Figure 3), and the interface definition is specified in Table 2.

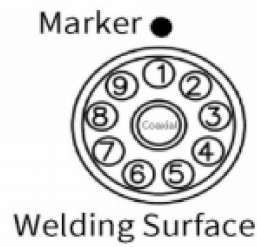

Figure 3 Connector Sequence Diagram

Table 2 Pin Definition of Product Sockets

S/N	Definition	Signal Type	Remarks
1	POWER	Input	Power input
2	PGND	Input	CAN high
3	CAN_H	Input/Output	CAN low
4	CAN_L	Input/Output	Analog video output
5	VIDEO	Output	Analog video reference ground
6	VGND	Output	RS232 receiving
7	RS232_RX	Input	RS232 sending
8	RS232_TX	Output	RS232 reference ground
9	GND	Reference ground	SDI output
Coaxial Core	SDI	Output	SDI
Coaxial Shell	GND	Reference ground	SDI output

### 3 Product Installation and Debugging

#### 3.1 Product Installation Methods

The product supports multiple installation options, including magnetic disk attachment and rigid installation with screws.

Note: For installation by magnetic disk attachment, consider the fastness of the attached surface to avoid surface deformation when the device is dismounted. For rigid installation with screws, take proper protective measures for the position where the device is in contact with the vehicle to avoid losses resulting from damage to the car paint.

##### 3.1.1 Disk-type

Step 1: Customers can purchase a magnetic disk of the appropriate size based on their vehicle's specifications and rigidly connect it to the product through a screw  $\phi 6.5$  in diameter, then attach the magnetic disk to the installation position. Please refer to Figure 4 for the mounting method.

Step 2: Adjust the angle. Loosen the four locking screws on the left and right sides of the bracket, and adjust the vertical angle of the product to the desired position, with an adjustable range of  $-10^{\circ}$  to  $10^{\circ}$ . The detailed adjustment instructions are shown in Figure 5.

Step 3: After angle adjustment, tighten the four screws on the left and right sides of the Spike-BF bracket to complete the installation.

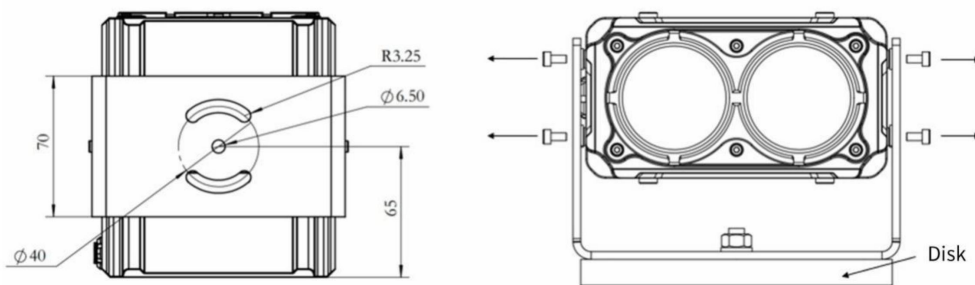

Figure 4 Disk Installation Diagram

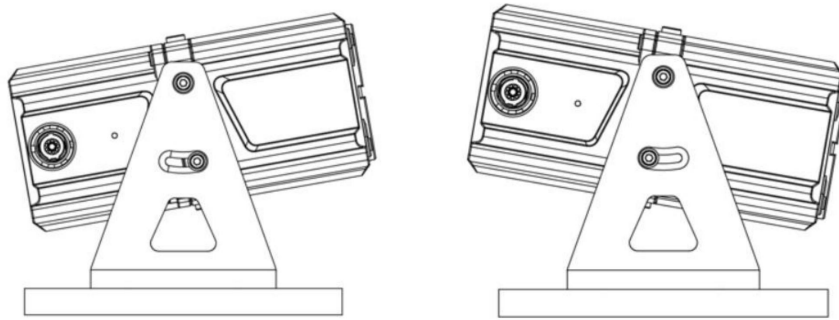

Figure 5 Angle Adjustment Diagram

### 3.1.2 Screw-type Rigid Installation with Brackets

When the Spike-BF cannot be installed by the magnetic disk method, it can be installed using bottom-mounting or top-hanging methods. The installation steps for both methods are the same. This section takes the bottom-mounting method as an example.

Step 1: Loosen the four screws on the left and right sides of the bracket and dismount the Spike-BF (see Figure 6).

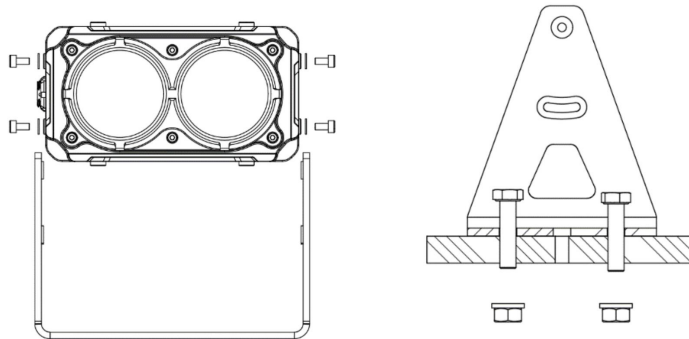

Figure 6 Disassembly of Bracket      Figure 7 Installation of Bracket

Step 2: Pierce the installation board with two M6\*30 Hex head screws and fasten them with nuts. While fixing the bracket, adjust the screws horizontally to a proper position before fastening the screws (see Figure 7).

Step 3: Install Spike-BF onto the bracket by fastening the four screws on the left and right sides. Adjust the vertical angle of the device. After that, fasten the four screws to complete the installation (see Figure 8).

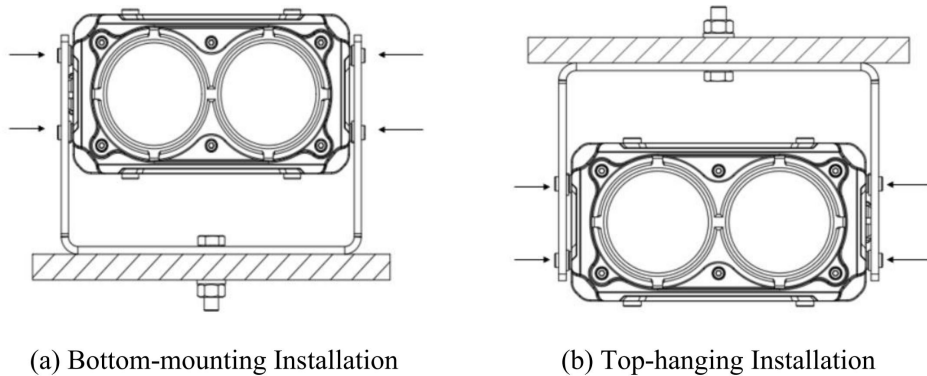

Figure 8 Product Installation Methods

### 3.1.3 Screw-type Rigid Installation without Brackets

If there is no need for pitch angle adjustment or if designing a custom bracket, the product's bracket may not be used. The product can be directly secured through the M3 threaded holes on its casing.

- Note: 1) When using this method, pay attention to the sunshade situation of the product;
- 2) This method is not recommended.

Step 1: Loosen the four screws on the left and right sides of the bracket and dismount the Spike-BF. See Figure 5.

Step 2: Use M3 screws to fix the threaded holes on the product. The installation diagram is shown in Figure 9.

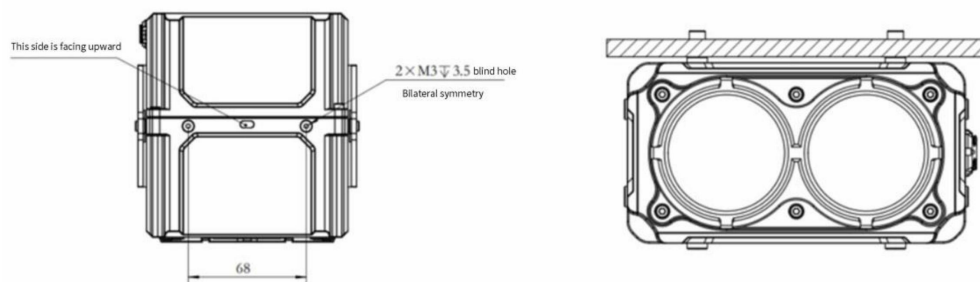

Figure 9 Fixing Mode of Product Shell

### **3.2 Product Cable Connection**

#### **3.2.1 Camera Connection**

Insert one end of the accompanying cable into the product's external interface and connect the other end to a dedicated display or customer terminal. (The dedicated display is customized by our company for the Spike B product series, which is optional.) Note: To connect the cable interface, align the connector with the white dot on the socket and then plug the connector in. The connector is plugged in when a crisp sound is heard. Figure 10 below shows the schematic of the connection.

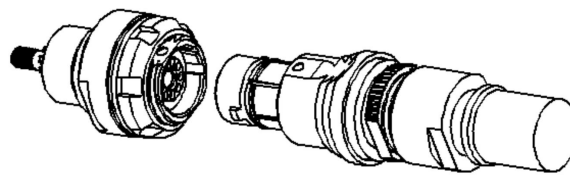

Figure 10 Schematic Diagram of Connector Connection

#### **3.2.2 Power Supply for the Product**

The product can be powered through the dedicated display. The display is powered by being connected to the vehicle through a car charger or by being connected to the vehicle's junction box through the male and female connectors of the car charger. If the power is supplied through a junction box, please note that the red cable of the bare wire of the car charger must be connected to the anode of the junction box and the black cable to the ground wire of the vehicle.

If the product is not used with a dedicated display, you can perform the power connection according to your needs using the power wire sequence on the cable.

## **4 Product Use and Operation**

When the product is used with the dedicated display, and when all cables are properly connected and the external power supply is in place, press the power button on the display to turn on the system. Operations and settings can also be performed through buttons and knobs on the display. For detailed operation methods, please refer to the Spike-BF Display User Manual.

When the product is used separately, its function operation and parameter setting can be carried out through the accompanying upper computer. For detailed information, please refer to the Spike B Upper Computer User Manual.



## 5 Common Faults and Troubleshooting

The following table shows the common faults of the product during use. Please check and fix the faults according to the methods in Table 3.

You need to check whether the faults are fixed after troubleshooting. Not all possible faults are listed in Table 3. If the unlisted faults occur or the faults cannot be fixed upon troubleshooting, please perform higher-level maintenance.

Table 3 Common Faults

S/N	Symptom	Reason	Troubleshooting Method
1	No image, black screen	Power failure	When equipped with a dedicated display, check whether the power switch on the display is turned on.
			Check whether the vehicle's power cables are properly connected, whether the cables are plugged in, and whether the power supply is normal.
			Check whether the power voltage provided by the vehicle is 9V to 32V. If not, ensure that the vehicle provides proper service voltage.
			Have the device repaired.
2	Fuzzy, unclear preview image	Stains on the lens	Wipe and clean the lens regularly with a dust-free cloth
		Stains on the display	Wipe and clean the display regularly with a dust-free cloth
			Have the device repaired.
3	Above the device's lens, there is snow accumulation or fogging.	Defrosting heating function failure	Ensure that the defrosting heating function is working. The power consumption of the device is 15W during normal heating. If the power consumption is less than 6W, it means that the function fails. Please have the device repaired.

## **6 Transportation and Storage**

The product, if packaged, can be transported by road, railway, and air. The device should be protected against rain, dust, sunlight, and impact during transportation and should be covered with tarpaulins if shipped in gondola cars.

The warehouse storing the device should be rainproof and dustproof, with humidity not higher than 80%. The warehouse should be free of acid, alkali, and corrosive gases, as well as strong mechanical vibration, impact, and strong magnetic field. Generally, the device shall be stored for less than six months. If the device is stored for a long time, power on the device for at least 3 hours for inspection every half a year.